

URBAN
Bonfire[™]

URBAIN

By

 **OASIS OUTDOOR LIVING**

YOUR KITCHEN OUTDOORS





Design Guide - Spring 2021

Table of Contents

04	Inspiring Designs
18	The Urban Bonfire™ By Oasis Outdoor Living Framework
19	Materials, Finishes and Hardware
25	Custom Design
30	Modules
45	Trims and Finished Panels
50	Request for Design
51	The Classics - Urban Bonfire™ By Oasis Outdoor Living
60	Planters
72	Compatibility
75	Technical Details



Contact

 www.OasisOutdoorLiving.com
 sales@oasisoutdoorliving.com
 1 (844) 627-4758

Welcome to Urban Bonfire™ By Oasis Outdoor Living™

Urban Bonfire™ by Oasis Outdoor Living designs and manufactures functional, beautiful and high-performance outdoor kitchen and entertainment solutions for clients around the world. With a fully integrated in-house design team, efficient manufacturing and compatibility with most major outdoor appliances and countertop surfaces, Urban Bonfire™ by Oasis Outdoor Living is the market leader in outdoor space activation centered around family, friends, food and lasting memories.

Each Urban Bonfire™ by Oasis Outdoor Living outdoor kitchen system features a wide array of functional, aesthetic and finishing options to choose from. Every custom layout and design is configured to maximize outdoor cooking and entertainment space while offering versatility, integrated storage and a carefully curated series of colors, handles and finishing choices.





INSPIRING DESIGNS



The ADAMO from our Custom Collection

Presented with Kalamazoo appliances, Dekton® countertop in Vera, powder coating in Artesan and stainless steel handles.



The ALGARVE from our Custom Collection

Presented with Caliber appliances, Dekton® countertop in Strato, powder coating in Onyx and bronze Pull handles in White Bronze finish.



The LAKESHORE 36 M from our Classics Collection

Presented with Blaze appliances, Dekton® countertop in Portum, powder coating in Clay with matching powder coated stainless steel handles.



The MARBELLA from our Custom Collection

Presented with Hestan Outdoors appliances, Dekton® countertop in Fossil, powder coating in Chantilly, stainless steel handles and our Cube Planter.



The MIRAMAR from our Custom Collection

Presented with True appliances, Dekton® countertop in Nilium, powder coating in Artesan and Urban handles in Light Bronze finish.



The MIRALANI from our Custom Collection

Presented with Hestan Outdoors appliances, Dekton® countertop in Opera, powder coating in Chantilly and powder coated stainless steel handles in Onyx.



The MESA from our Custom Collection

Presented with Wolf appliances, Dekton® countertop in Opera, powder coating in Anthracite and bronze Bauhaus handles in White Bronze finish.



The PRAIRIE 42 M from our Classics Collection

Presented with DCS appliances, Dekton® countertop in Fossil, powder coating in Pewter and stainless steel handles.



The REGATTA from our Custom Collection

Presented with Twin Eagles appliances, Dekton® countertop in Lunar, powder coating in Onyx and Pull handles in Light Bronze finish.



The SANTA FE from our Custom Collection

Presented with Lynx appliances, Dekton® countertop in Lunar, powder coating in Chantilly and stainless steel handles.



The SPRING 42 from our Classics Collection

Presented with Alfresco appliances, Dekton® countertop in Nilium, powder coating in Clay with matching powder coated stainless steel handles.



The TUSCAN from our Custom Collection

Presented with Evo and Hestan beer dispenser, Dekton® countertop in Opera, powder coating in Anthracite and bronze Pull handles in Black Bronze finish.



The VISTA from our Custom Collection

Presented with Coyote appliances, Dekton® countertop in Lunar, powder coating in Artesan and bronze Bauhaus handles in White Bronze finish.

The Urban Bonfire™ By Oasis Outdoor Living Framework

Construction

- Non-combustible thick gauge marine grade aluminum
- Outdoor grade 304 stainless steel hardware

Integrated Backsplash System

- Extruded aluminum with electrostatic powder coating
- Matching Clip-in Planters and accessories available

Customizable

- Super durable electrostatic powder coating included on all cabinets, planters and accessories
- Carefully curated designer-inspired color options and "living finish" bronze handles upgrades available in various shapes and tones

Planter Boxes

- Fully welded, powder coated marine grade aluminum
- Curated series with custom shapes, height and sizes available

Compatibility

- Custom trim kits for compatibility with most major outdoor appliances brands and models
- Ready to receive Dekton® and other outdoor-rated countertop materials

Universal Track System

- Numerous interior accessory options allow for easy customization
- Maximized efficiency, functionality and usage of every cabinet

A Solid Foundation

- Commercial grade stainless steel leveling legs
- Self-leveling toe kick that adapts to slope and outdoor site conditions



MATERIALS, FINISHES AND HARDWARE

Materials and Finishes



Marine Grade Aluminum

Non-combustible, thick gauge marine grade aluminum construction for all Urban Bonfire™ By Oasis Outdoor Living cabinets, planters, accessories and backsplash systems.

Urban Bonfire™ By Oasis Outdoor Living's marine grade aluminum is twice as thick as most stainless steel cabinetry on the market, yet lighter in weight. Aluminum is easy to transport and cooperates well during installations. It is the ideal material for extreme climates (snow, ice, salt water, humidity) and long-term quality.



304 Stainless Steel Hardware

We use outdoor grade 304 stainless steel for our door slides, hinges, pulls and leveling legs.

NACRAĒ™

Urban Bonfire™ By Oasis Outdoor Living's **NACRAĒ™** finish was inspired by the beauty, strength and resilience of mother-of-pearl. Each finish is crafted with a micro textured formulation that preserves and protects beauty, creating a stable depth of color in all climates and any outdoor environment.

Now with revolutionary, all natural, **anti-microbial** protection.



NACRAĒ is engineered for life outdoors.

Standard feature on all Urban Bonfire™ By Oasis Outdoor Living products



Durable, 4-season formulation that resists scratches, fading and stains even in harsh climates.



FDA approved and environmentally sustainable material and process.



Integrated all-natural anti-microbial properties for maximum safety and freshness.



A collection of specialty colors developed in collaboration with iconic designers.

Powder Coating Options

Our custom formulated “Super Durable” finishes are applied to AAMA 2604 standards. A slight textured finish adds depth to the color and resists fingerprints. Available in 6 curated designer-inspired colors.



Onyx

A deep, dark black that is sure to create a standout piece in any environment.



Anthracite

Modern dark gray with a slate undertone that works beautifully in concrete and contemporary urban environments.



Artesan

A dark gray finish with a warm bronze undertone. Designed to accent wood and natural limestone while still creating a welcome contrast through its depth of tone.

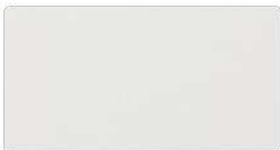

Chantilly

This crisp white works in almost any outdoor setting. Reflecting tones of silk and clean linen.



Clay

An elegant and versatile rich beige. Enhances the mood and atmosphere of any classic outdoor living space.



Pewter

Warm dark gray with bronze undertones. Adds a refined touch to any outdoor environment.

Handle Options

Each cabinet includes our premium outdoor grade **304 stainless steel handle**. For added personalization and design, handle upgrades in powder coated finishes are available (optimal choice for heavy saltwater climates).



Stainless Steel
(included)

Upgrade Options Powder Coating Colors



Onyx



Anthracite



Artesan



Chantilly



Clay



Pewter

Upgrade Options

“Living Finish” Bronze Handles

For added personalization and design, handle upgrades in solid bronze are available. Our “living finishes” will weather over time as natural bronze changes tone and character as it gains charm.

Model

Pull Handle (H-341)

Urban Handle (H-337)

Bauhaus Handle (H-3312)



**White Bronze
(WL)**



**Light Bronze
(LT)**



**Black Bronze
(BZ)**



**Pull
Handle**



**Urban
Handle**

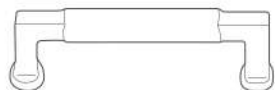

**Bauhaus
Handle**





CUSTOM DESIGN

Our Custom Design Process

We are dedicated to creating designs that are expressions of our clients' individuality. This passion for creative design makes the art of developing custom outdoor kitchen solutions highly engaging and interactive. We believe that custom outdoor kitchen systems should reflect the lifestyle, aesthetic and spatial parameters of every individual client.

Work with a member of our passionate and professional design team to experience your outdoor cooking and entertainment space possibilities.



Before We Start...

Gather basic dimensions of your space, plans, sketches, inspirational photos and any additional ideas for the vision of your space.

Step 1 Start Your Design Process

Your custom design process begins with a one-on-one virtual consultation with a dedicated Urban Bonfire™ By Oasis Outdoor Living designer to gather information about your lifestyle, aesthetic preferences and basic spatial parameters of your new outdoor room.

“How will your outdoor space integrate with the indoors for day to day and larger entertainment uses?”

“What types of cooking do you enjoy and for how many people?”

“What types of activities do you hope to enjoy in your new outdoor living space?”

This will allow our team to determine the most appropriate layout and materials and present a custom solution that incorporates selected outdoor cooking appliances with integrated storage, functionality and counter space.

Try our simple **Request for Design** form as a first step to planning your new outdoor space and prepare for your consultation.

Our design team will work with you and/or your design professional to develop a preliminary layout that can be modified as necessary to meet with most spacial, aesthetic and budgetary parameters.

Step 2 Design & Planning

Following the initial consultation, our design team will create a personalized proposal for your project.

Our proposal includes beautiful 3D renderings and 2D plans, as well as a detailed quote for your project. Appliances and countertop sold separately.

Design proposals are presented in a comprehensive package via a virtual meeting with your Urban Bonfire™ designer.

Step 3

Production

Once the design is approved, we begin producing your kitchen. Lead times are typically about 6 weeks. US clients receive orders from the distribution center located in Champlain, NY.

Step 4

Quality Control & Packaging

Upon completion of our production process, each project must pass quality control and staging before final crating and shipping. With your kitchen staged in our bright assembly facility, each cabinet is inspected and numbered in accordance with your custom designed plan. With final inspection and staging complete, the fully assembled cabinets are packaged in their own, custom made, packaging and prepared for shipping.

Included in the Urban Bonfire™ By Oasis Outdoor Living experience



Personalised Service from one of our Elite Designers



1-3 Initial Concepts



Technical 2D Plans and 3D Renderings



Final Design



MODULES

Grill Base Cabinets

Thick marine grade aluminum construction. All outdoor grade 304 stainless steel hardware. Includes self-leveling toe kick, choice of powder coating and solid 304 stainless steel round handles. Grill base cabinets are specified 4" - 6" larger than the grill specified.

Model

36" Grill Base Cabinet (A-GB36)

42" Grill Base Cabinet (A-GB42)

48" Grill Base Cabinet (A-GB48)

62" Grill Base Cabinet (A-GB62)



The custom **trim kit** allows the cabinet to professionally integrate with most major outdoor appliance brands and sizes.

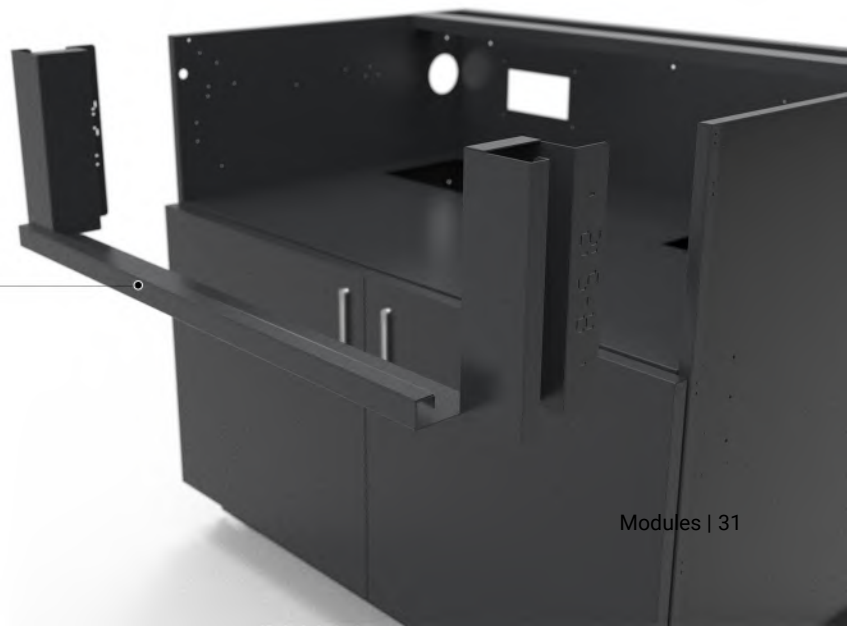



Optional Feature

Warming Drawer Insert

Structural insert for warming drawers. Made of thick marine grade construction and includes choice of powder coating. To see all compatible models, see our **Compatibility chart** in our Resources section on [urbanbonfire.com](https://www.urbanbonfire.com)

Model

A-FP-GB36

A-FP-GB42

A-FP-GB48

A-FP-GB62

Side and Power Burner Cabinets

Thick marine grade aluminum construction. All outdoor grade 304 stainless steel hardware. Includes self-leveling toe kick, choice of powder coating and solid outdoor grade 304 stainless steel round handles. Single, Dual and Power Burner cabinets are specified 6" larger than the appliance.

Model

21" Side Burner Cabinet (A-BB21)

30" Power Burner Cabinet (A-BB30)



Space for conduits



Custom trim kit

Kamado Cabinets

Kamado style smoker cabinet. Thick marine grade aluminum construction. Includes self-leveling toe kick and choice of powder coating.

Model

27" Closed Kamado Cabinet (A-BE27-C)

27" Open Kamado Cabinet (A-BE27-O)

33" Open Kamado Cabinet (A-BE33-O)



For best results, a piece of countertop should be planned underneath the base and Kamado "feet" should be used.

Utility Cabinets

Utility base storage cabinet with Universal Track keyhole system for accessories. Thick marine grade aluminum construction. All outdoor grade 304 stainless steel hardware. Includes self-leveling toe kick, choice of powder coating and solid outdoor grade 304 stainless steel round handles.

Model

12" Utility Cabinet (A-BF12-U)

18" Utility Cabinet (A-BF18-U)

21" Utility Cabinet (A-BF21-U)

24" Utility Cabinet (A-BF24-U)

30" Utility Cabinet (A-BF30-U)

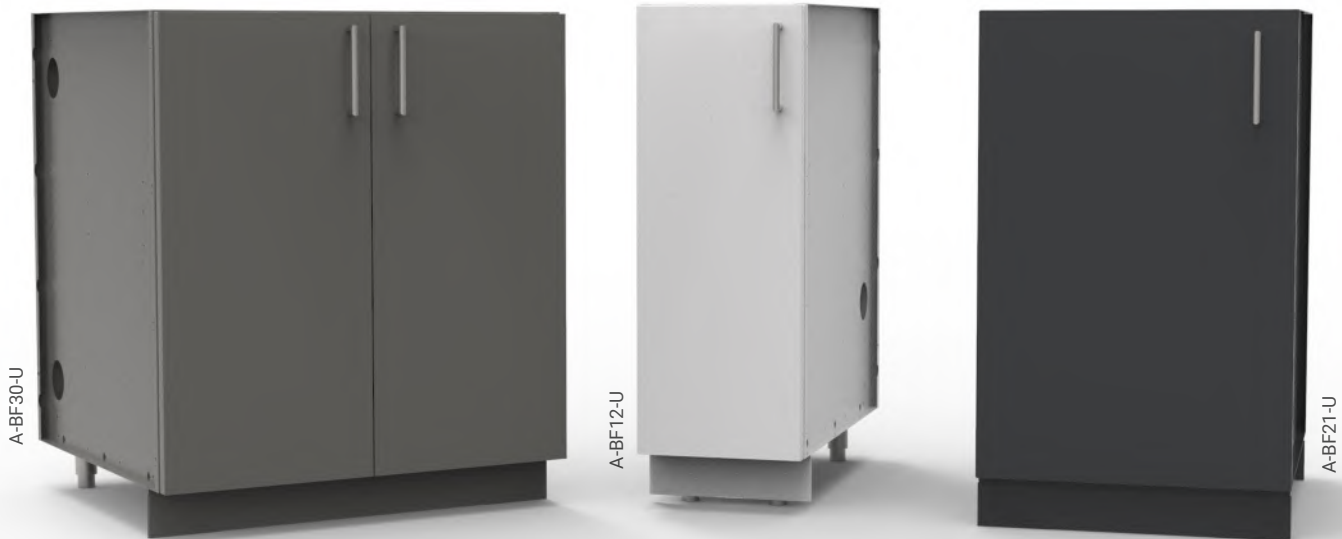

Universal Track System

Every utility cabinet includes our Universal Track System, to allow for easy customization and maximize the efficiency and functionality.

Large Utility Cabinets **NEW**

Utility base storage cabinet with Universal Track keyhole system for accessories. Thick marine grade aluminum construction. All outdoor grade 304 stainless steel hardware. Includes self-leveling toe kick, choice of powder coating and solid outdoor grade 304 stainless steel round handles.

Model

36" Utility Cabinet (A-BF36-U)

42" Utility Cabinet (A-BF42-U)

48" Utility Cabinet (A-BF48-U)



A-BF36-U

A-BF42-U

A-BF48-U



A-BF48-U. Shown with A-SHELF48.

Accessories for Utility Cabinets



Pull-Out Storage Peg System (A-PEG12)

(shown with A-DR12)



Heavy Duty Retractable Drawer Accessory

(up to three per cabinet)

12" Heavy Duty Retractable Drawer (A-DR12)

18" Heavy Duty Retractable Drawer (A-DR18)

21" Heavy Duty Retractable Drawer (A-DR21)

24" Heavy Duty Retractable Drawer (A-DR24)

30" Heavy Duty Retractable Drawer (A-DR30)



Full Depth Adjustable Height Shelf

(up to two per cabinet)

12" Full Depth Shelf (A-SHELF12)

18" Full Depth Shelf (A-SHELF18)

21" Full Depth Shelf (A-SHELF21)

24" Full Depth Shelf (A-SHELF24)

30" Full Depth Shelf (A-SHELF30)

36" Full Depth Shelf (A-SHELF36)

42" Full Depth Shelf (A-SHELF42)

48" Full Depth Shelf (A-SHELF48)



Pull-out Refuse and Recycling Accessory

(shown with A-DR21)

12" Pull-out Refuse and Recycling Accessory (A-GBG12)

18" Pull-out Refuse and Recycling Accessory (A-GBG18)

21" Pull-out Refuse and Recycling Accessory (A-GBG21)

24" Pull-out Refuse and Recycling Accessory (A-GBG24)

Storage Cabinet with Single Drawer **NEW**

Storage cabinet equipped with single drawer, stainless steel soft close drawer slides and centered shelf. Thick marine grade aluminum construction. All outdoor grade 304 stainless steel hardware. Includes self-leveling toe kick, choice of powder coating and solid outdoor grade 304 stainless steel round handles.

Model

18" Storage Cabinet with Single Drawer (A-BR18)

21" Storage Cabinet with Single Drawer (A-BR21)

24" Storage Cabinet with Single Drawer (A-BR24)



Elegant storage capacity for multiple items such as plates, utensils, cookware and more.

Pull-out Refuse Cabinet with Single Drawer **NEW**

Pull-out refuse cabinet with single top drawer, equipped with stainless steel soft close drawer slides and two (2) heavy duty plastic refuse bins. Thick marine grade aluminum construction. All outdoor grade 304 stainless steel hardware. Includes self-leveling toe kick, choice of powder coating and solid outdoor grade 304 stainless steel round handles.

Model

18" Pull-out Refuse Cabinet with Single Drawer (A-BG18)

21" Pull-out Refuse Cabinet with Single Drawer (A-BG21)

24" Pull-out Refuse Cabinet with Single Drawer (A-BG24)



Sink Cabinets

Thick marine grade aluminum construction. All outdoor grade 304 stainless steel hardware. Includes self-leveling toe kick, choice of powder coating and solid outdoor grade 304 stainless steel round handles.

Model

12" Sink Cabinet (A-BF12-S)

18" Sink Cabinet (A-BF18-S)

21" Sink Cabinet (A-BF21-S)

24" Sink Cabinet (A-BF24-S)

30" Sink Cabinet (A-BF30-S)

36" Sink Cabinet (A-BF36-S)

42" Sink Cabinet (A-BF42-S)

48" Sink Cabinet (A-BF48-S)



Undercounter Appliance Kits

Structural finishing kits for outdoor refrigerators, ice makers, keg tappers or freezers. Thick marine grade aluminum construction. Includes front countertop support spacer and back spacing panel, self-leveling toe kick and choice of powder coating.

Model

15" Undercounter Appliance Kit (A-FRDG15)

18" Undercounter Appliance Kit (A-FRDG18)

20 ³/₄" Undercounter Appliance Kit (A-FRDG20.75)

21 ¹/₂" Undercounter Appliance Kit (A-FRDG21.5)

22" Undercounter Appliance Kit (A-FRDG22)

24" Undercounter Appliance Kit (A-FRDG24).

28 ¹/₂" Undercounter Appliance Kit (A-FRDG28.5)

30" Undercounter Appliance Kit for two 15" combination (A-FRDG30)

36" Reinforced Undercounter Appliance Kit (A-FRDGRIN36)

39" Reinforced Undercounter Appliance Kit for one 24" and one 15" combination (A-FRDGRIN-39)

48" Reinforced Undercounter Appliance Kit for two 24" combination (A-FRDGRIN-48)

24 ⁷/₈" Dishwasher Kit (A-DW24.875)

Front countertop support spacer



Undercounter Appliance Overlay Panels

Give a seamless look to your outdoor kitchen with appliance overlay panels. Available for 15" and 24" undercounter appliances. Handle included separately, to be installed on site. Panel fabricated to the specifications provided by appliance manufacturer.

Models

A-FPANEL-15
A-FPANEL-15-2DRAWER
A-FPANEL-24
A-FPANEL-24-2DRAWER

*For compatible appliance brands, see our [Compatibility Chart](#) in our Resources section at urbanbonfire.com



Spacer Module

4" module designed for added structural support of countertop if/where applicable. Includes self-leveling toe kick and choice of powder coating. Available with or without cutout for waterproof plug box and cover (supplied and installed by local electrician).

Model

4" Cutout Spacer Module (A-BF4)
4" Spacer Module (A-BF4-C)



Corner Module

32 ³/₄" corner support module. Thick marine grade aluminum construction. Includes self-leveling toe kick and choice of powder coating.

Model

32 ³/₄" Corner Module (A-CRNR)



Flush Mount Cabinet

21" flush mount drawer cabinet with full depth heavy duty drawers (3) and stainless steel soft close slides. Thick marine grade aluminum construction. All outdoor grade 304 stainless steel hardware. Includes self-leveling toe kick, choice of powder coating and outdoor grade solid 304 stainless steel round handles.

Model

21" Flush Mount Cabinet (A-BD21)



Open Shelving Cabinets

Flexible storage for cooking and entertaining needs. Ideal for platters, plates, glasses and more. Thick marine grade aluminum construction. Includes self-leveling toe kick, choice of oiled natural IPE wood or powder coated marine grade aluminum internal slats.

Model

24" Open Shelving Cabinet (A-B024-M)

24" Open Shelving Cabinet (A-B024-W)

27" Open Shelving Cabinet (A-B027)

Slats Material

Marine grade aluminum

IPE wood



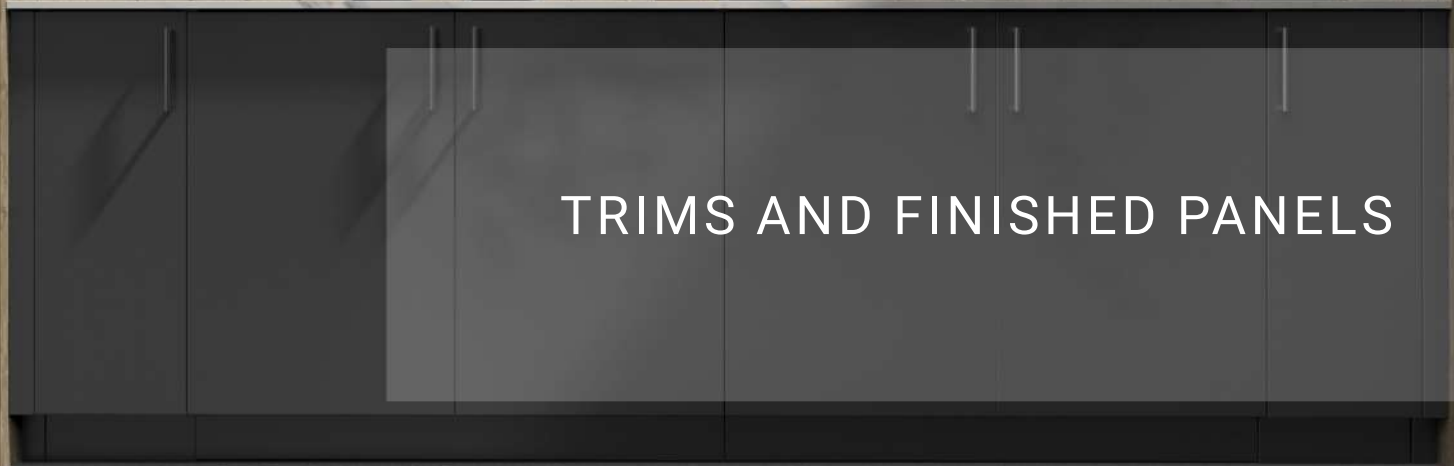

TRIMS AND FINISHED PANELS

Side Trims

Custom fillers for outdoor kitchens that are between walls. Thick marine grade aluminum construction and includes choice of powder coating.

Model	Width
Filler Style	$\frac{3}{4}$ " - 2"
Panel Style	2 $\frac{1}{4}$ " and over

Filler Style

Full height single piece trim filler. To be cut to height and fastened to cabinet side during installation.

$\frac{3}{4}$ " - 2" wide.



Panel Style

Custom filler panel. Includes self-leveling toe kick and choice of powder coating.

2 $\frac{1}{4}$ " wide and over.



Full Length Toe Kicks

Full length toe kick for a seamless look. Thick marine grade aluminum construction and includes choice of powder coating. To be cut to size on site.

Model	Length	Height
Full Length Toe Kick (A-FULLTK-96x7).....	96"	7"
Corner for Full Length Toe Kick (A-FULLTK-CRNRx7)		7"



Regular Toe Kicks

Regular front toe kicks. Thick marine grade aluminum construction and choice of powder coating. Included with each cabinet. Adapts to slope and outdoor site conditions.



Finished Panels

Back Panels

Aesthetic finished back panel. Thick marine grade aluminum construction. Includes self-leveling toe kick and choice of powder coating. Only required when the back of the kitchen is visible.

Model

- 12" Back Panel (A-BCKP12)
- 18" Back Panel (A-BCKP18)
- 21" Back Panel (A-BCKP21)
- 24" Back Panel (A-BCKP24)
- 27" Back Panel (A-BCKP27)
- 30" Back Panel (A-BCKP30)
- 33" Back Panel (A-BCKP33)
- 36" Back Panel (A-BCKP36)
- 42" Back Panel (A-BCKP42)
- 48" Back Panel (A-BCKP48)
- 62" Back Panel (A-BCKP62)
- Corner Back Panel (A-BCKP-CRNR)

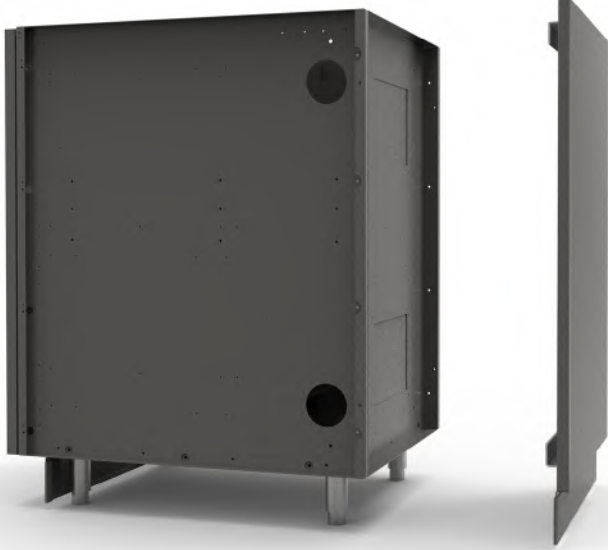

End Panels

Aesthetic finished end panel. Thick marine grade aluminum construction. Includes self-leveling toe kick and choice of powder coating. Only required when the side(s) of the kitchen are visible.

Model

- 28 ³/₄" End Panel (A-ENDP28)
- 32" End Panel (A-ENDP32)
- 38 ⁵/₈" End Panel (A-ENDP38)



Louvered Back Panels

Aesthetic louvered ventilated finished back panel.
Thick marine grade aluminum construction.
Includes self-leveling toe kick and choice of
powder coating.

Model

- 21" Louvered Back Panel (A-BCKP21-V)
- 30" Louvered Back Panel (A-BCKP30-V)
- 36" Louvered Back Panel (A-BCKP36-V)
- 42" Louvered Back Panel (A-BCKP42-V)
- 48" Louvered Back Panel (A-BCKP48-V)
- 62" Louvered Back Panel (A-BCKP62-V)

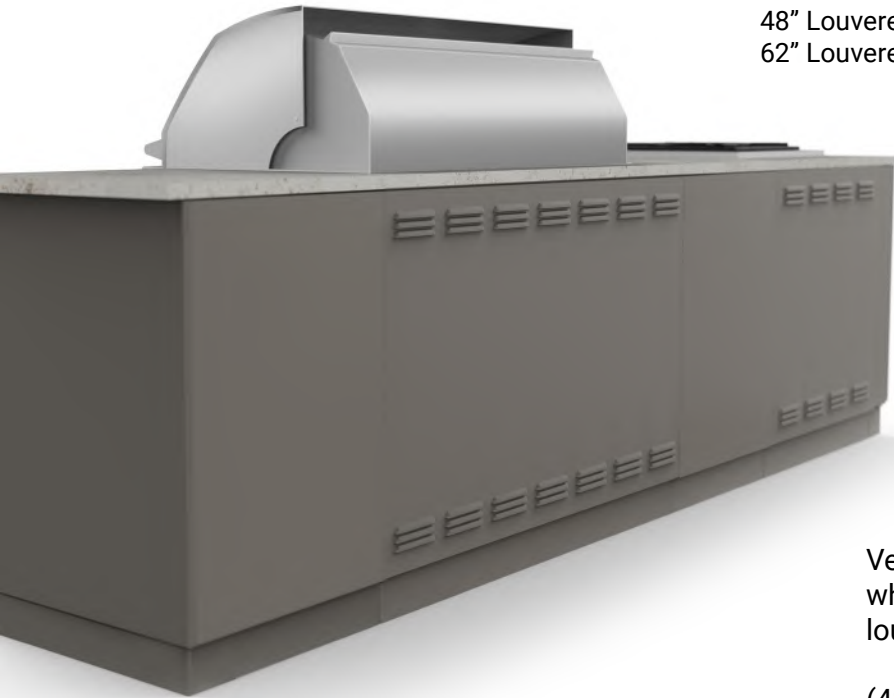

Ventilated back panels create a finished look
when back of kitchen is visible. Equipped with
louvered slats for equipment venting.

(48" and 30" shown)



Venting requirements may vary based on site
conditions, local codes, equipment specifications
and gas types. Check with your local licensed
professional to ensure full and complete
compliance to codes.



THE CLASSICS
URBAN BONFIRE™
BY OASIS OUTDOOR LIVING

“The Classics” - Urban Bonfire™ By Oasis Outdoor Living

Urban Bonfire™ By Oasis Outdoor Living's Classics program offers a series of our most popular outdoor kitchen configurations, colors and accessories. Every “Classics” outdoor kitchen includes a professional Dekton® Countertop template and is compatible with most industry leading outdoor grill and appliance brands.



Powder Coating Finishes

Our custom formulated “Super Durable” finishes add depth to the colors and resistance to fingerprints.

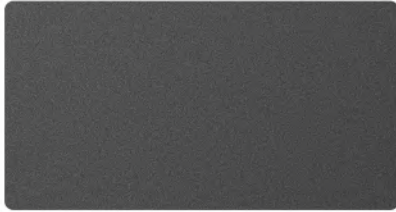

Anthracite

Modern dark gray with slate undertones. Elevates contemporary and outdoor urban environments.

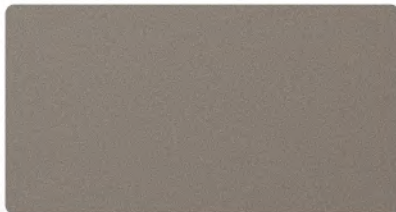

Clay

An elegant and versatile rich beige. Enhances the mood and atmosphere of any classic outdoor living space.



Pewter

Warm dark gray with bronze undertones. Adds a refined touch to any outdoor environment.

Powder Coated Handles

Each “Classics” kitchen includes both our basic and fully powder coated, matching, outdoor grade 304 stainless steel handles.

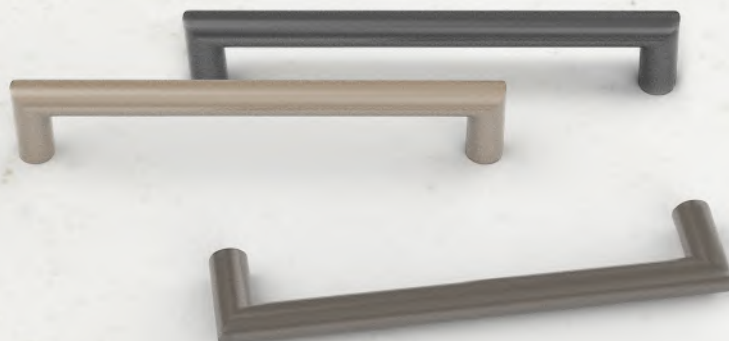

Sierra Series



S-SIERRA36

*Length 87"
Depth 28 ³/₄"
Height 36 ¹/₂" (± 1")

Presented in Clay with Dekton® Edora (2cm) and Alfresco appliance.**



S-SIERRA42

*Length 93"
Depth 28 ³/₄"
Height 36 ¹/₂" (± 1")

Shown in Pewter with Dekton® Fossil (2cm) and Aspire by Hestan appliance.**

* Including ³/₄" countertop nosing.

**Countertop and appliances are sold separately.

Horizon Series



S-HORIZON36

*Length 111"
Depth 28 ³/₄"
Height 36 ¹/₂" (± 1")

Presented in Anthracite with Dekton® Nilium (2cm) and Blaze appliances.**



S-HORIZON36M

*Length 111"
Depth 28 ³/₄"
Height 36 ¹/₂" (± 1")

Presented in Clay with Dekton® Opera (2cm) and Coyote appliances.**



S-HORIZON42

*Length 117"
Depth 28 ³/₄"
Height 36 ¹/₂" (± 1")

Presented in Pewter with Dekton® Edora (2cm) and DCS appliances.**



S-HORIZON42M

*Length 117"
Depth 28 ³/₄"
Height 36 ¹/₂" (± 1")

Presented in Anthracite with Dekton® Vera (2cm) and Hestan Outdoors appliances.**

* Including ³/₄" countertop nosing.

**Countertop and appliances are sold separately.

Prairie Series



S-PRAIRIE36

*Length 111"
Depth 28 3/4"
Height 36 1/2" (± 1")

Presented in Clay with Dekton® Portum (2cm) and Lynx Professional appliance.**



S-PRAIRIE36M

*Length 111"
Depth 28 3/4"
Height 36 1/2" (± 1")

Presented in Pewter with Dekton® Nilium (2cm) and Sedona by Lynx appliance.**



S-PRAIRIE42

*Length 117"
Depth 28 3/4"
Height 36 1/2" (± 1")

Presented in Anthracite with Dekton® Opera (2cm) and Twin Eagles appliance.**



S-PRAIRIE42M

*Length 117"
Depth 28 3/4"
Height 36 1/2" (± 1")

Presented in Clay with Dekton® Edora (2cm) and Wolf appliance.**

* Including 3/4" countertop nosing.

**Countertop and appliances are sold separately.

Lakeshore Series



S-LAKESHORE36

*Length 132"
Depth 28 3/4"
Height 36 1/2" (± 1")

Presented in Pewter with Dekton® Fossil (2cm) and Alfresco appliances.**



S-LAKESHORE36M

*Length 132"
Depth 28 3/4"
Height 36 1/2" (± 1")

Presented in Anthracite with Dekton® Portum (2cm) and Aspire by Hestan appliances.**



S-LAKESHORE42

*Length 138"
Depth 28 3/4"
Height 36 1/2" (± 1")

Presented in Clay with Dekton® Fossil (2cm) and Blaze appliances.**



S-LAKESHORE42M

*Length 138"
Depth 28 3/4"
Height 36 1/2" (± 1")

Presented in Pewter with Dekton® Opera (2cm) and Coyote appliances.**

* Including 3/4" countertop nosing.

**Countertop and appliances are sold separately.

Spring Series



S-SPRING36

*Length 132"
Depth 28 3/4"
Height 36 1/2" (± 1")

Presented in Anthracite with Dekton® Nilium (2cm) and DCS appliances.**



S-SPRING36M

*Length 132"
Depth 28 3/4"
Height 36 1/2" (± 1")

Presented in Clay with Dekton® Edora (2cm) and Hestan Outdoors appliances.**



S-SPRING42

*Length 138"
Depth 28 3/4"
Height 36 1/2" (± 1")

Presented in Pewter with Dekton® Nilium (2cm) and Lynx Professional appliances.**



S-SPRING42M

*Length 138"
Depth 28 3/4"
Height 36 1/2" (± 1")

Presented in Anthracite with Dekton® Vera (2cm) and Sedona by Lynx appliances.**

* Including 3/4" countertop nosing.

**Countertop and appliances are sold separately.

Coral Series



S-CORAL36

*Length 135"
Depth 28 3/4"
Height 36 1/2" (± 1")

Presented in Clay with Dekton® Opera (2cm) and Wolf appliances.**



S-CORAL36M

*Length 135"
Depth 28 3/4"
Height 36 1/2" (± 1")

Presented in Pewter with Dekton® Fossil (2cm) and Twin Eagles appliances.**



S-CORAL42

*Length 141"
Depth 28 3/4"
Height 36 1/2" (± 1")

Presented in Anthracite with Dekton® Portum (2cm) and Alfresco appliances.**



S-CORAL42M

*Length 141"
Depth 28 3/4"
Height 36 1/2" (± 1")

Presented in Clay with Dekton® Edora (2cm) and Aspire by Hestan appliances.**

* Including 3/4" countertop nosing.

**Countertop and appliances are sold separately.

Powder Coated Accessories

Pull-Out Drawer

S-DR Accessory (S-DR-1)

One Heavy Duty Drawer Accessory for the 21" utility cabinet. Compatible with the Universal Track System and can be mounted at various heights. Thick marine grade aluminum construction with Super Durable powder coated finish and all outdoor grade 304 stainless steel hardware.

S-DR Accessory Bundle (S-DR-2)

Two (2) Heavy Duty Drawer Accessory for the 21" utility cabinet. Compatible with the Universal Track System and can be mounted at various heights. Thick marine grade aluminum construction with Super Durable powder coated finish and all outdoor grade 304 stainless steel hardware.

S-DR Accessory Bundle (S-DR-3)

Three (3) Heavy Duty Drawer Accessory for the 21" utility cabinet. Compatible with the Universal Track System and can be mounted at various heights. Thick marine grade aluminum construction with Super Durable powder coated finish and all outdoor grade 304 stainless steel hardware.



Full Depth Shelf

S-SHELF Accessory (S-SHELF-1)

One (1) full depth shelf accessory for the 21" utility cabinet. Compatible with the Universal Track System and can be mounted at various heights. Thick marine grade aluminum construction with Super Durable powder coated finish and all outdoor grade 304 stainless steel hardware.

S-SHELF Accessory Bundle (S-SHELF-2)

Two (2) full depth shelf accessories for the 21" utility cabinet. Compatible with the Universal Track System and can be mounted at various heights. Thick marine grade aluminum construction with Super Durable powder coated finish and all outdoor grade 304 stainless steel hardware.



Refuse

S-GBG Accessory (S-GBG)

Pull-out refuse and recycling accessory for 21" utility cabinet. Includes 2 (18 qt.) plastic bins. Compatible with the Universal Track System and can be mounted at various heights. Thick marine grade aluminum construction with Super Durable powder coated finish and all 304 stainless steel hardware.

S-DR and S-GBG Accessory Bundle (S-DR-GBG)

Includes one (1) pull-out refuse and recycling accessory and one (1) heavy duty pull-out drawer accessory. Thick marine grade aluminum construction with Super Durable powder coated finish and all outdoor grade 304 stainless steel hardware.





PLANTERS

Countertop Planter

Designed for small herb gardens or annuals, this planter sits directly on the countertop. Fully welded and made of thick marine grade aluminum. Includes choice of powder coating in any one of our standard colors.



Model

	MSRP
18 x 6 x 8" Countertop Planter (A-PLANTER-COUNTER-18x6x8)	USD \$545
24 x 6 x 8" Countertop Planter (A-PLANTER-COUNTER-24x6x8)	USD \$585
30 x 6 x 8" Countertop Planter (A-PLANTER-COUNTER-30x6x8)	USD \$625



A-PLANTER-COUNTER-18x6x8



A-PLANTER-COUNTER-24x6x8



A-PLANTER-COUNTER-30x6x8

Technical Details - Cube, Partition & Trough Planters

Fully welded thick marine grade aluminum, powder coated and built to last. The drainage holes at the base ensure proper drainage and prevent over watering. Our series of Countertop Planters are designed for a minimal and sleek look, ideal for herbs, flowers and other annuals.



Cube Planter

Designed to fill a space without adding extra storage, a Cube Planter is a beautiful and functional addition to an outdoor kitchen. Freestanding, fully welded and made of thick marine grade aluminum. Includes choice of powder coating in any one of our standard colors.

Model

18 x 18 x 18" Cube Planter
(A-PLANTER-CUBE-18x18x18)

21 x 21 x 21" Cube Planter
(A-PLANTER-CUBE-21x21x21)

24 x 24 x 24" Cube Planter
(A-PLANTER-CUBE-24x24x24)

28 x 28 x 28" Cube Planter
(A-PLANTER-CUBE-28x28x28)

36 x 36 x 36" Cube Planter
(A-PLANTER-CUBE-36x36x36)



A-PLANTER-CUBE-18x18x18



A-PLANTER-CUBE-21x21x21

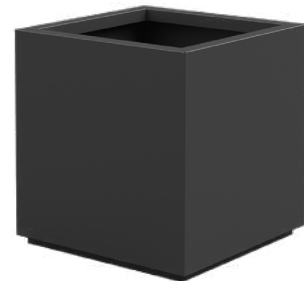

A-PLANTER-CUBE-24x24x24

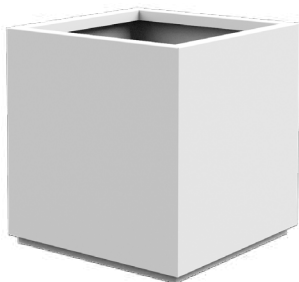

A-PLANTER-CUBE-28x28x28



A-PLANTER-CUBE-36x36x36

Partition Planter

Designed for placement behind a kitchen to create a freestanding “living” backsplash structure, Partition Planters are also ideal for delineating a space and creating more intimate environments.

Our Partition Planters offer the option of having an indented u-channel base to give a subtle elevation.

Option for direct ground placement (as shown below) is also available and creates a seamless backdrop to your Urban Bonfire™ kitchen.



Model

36 x 10 x 42" Partition Planter (A-PLANTER-PARTITION-36x10x42)

36 x 10 x 42" Partition Planter No U-Channel (A-PLANTER-PARTITION-36x10x42-NC)

42 x 12 x 42" Partition Planter (A-PLANTER-PARTITION-42x12x42)

42 x 12 x 42" Partition Planter No U-Channel (A-PLANTER-PARTITION-42x12x42-NC)



A-PLANTER-PARTITION-42x12x42-NC



A-PLANTER-PARTITION-42x12x42



A-PLANTER-PARTITION-36x10x42



A-PLANTER-PARTITION-36x10x42-NC



A-PLANTER-PARTITION-42x12x42



A-PLANTER-PARTITION-42x12x42-NC

Trough Planter

Designed for lower gardening plots, or as a convenient sitting space, a Trough Planter adds form and function to an outdoor environment. Freestanding, fully welded and made of thick marine grade aluminum. Includes choice of powder coating.



A-PLANTER-TROUGH-36x24x7



A-PLANTER-TROUGH-48x18x10



A-PLANTER-TROUGH-48x24x9

Model

- 36 x 24 x 7" Trough Planter (A-PLANTER-TROUGH-36x24x7)
- 48 x 18 x 10" Trough Planter (A-PLANTER-TROUGH-48x18x10)
- 48 x 24 x 9" Trough Planter (A-PLANTER-TROUGH-48x24x9)
- 48 x 24 x 20" Trough Planter (A-PLANTER-TROUGH-48x24x20)
- 24 x 24" IPE Wood Bench Planter (A-PLANTER-WOODBENCH-24x24)



A-PLANTER-TROUGH-48x24x20



A-PLANTER-WOODBENCH-24x24

(Shown with A-PLANTER-TROUGH-48x24x20)

Technical Details - Cube, Partition & Trough Planters

Fully welded thick marine grade aluminum, powder coated and built to last. Each Cube, Partition and Trough Planter comes equipped with pre-machined drainage holes and 1 ½" geotextile covered insulation.

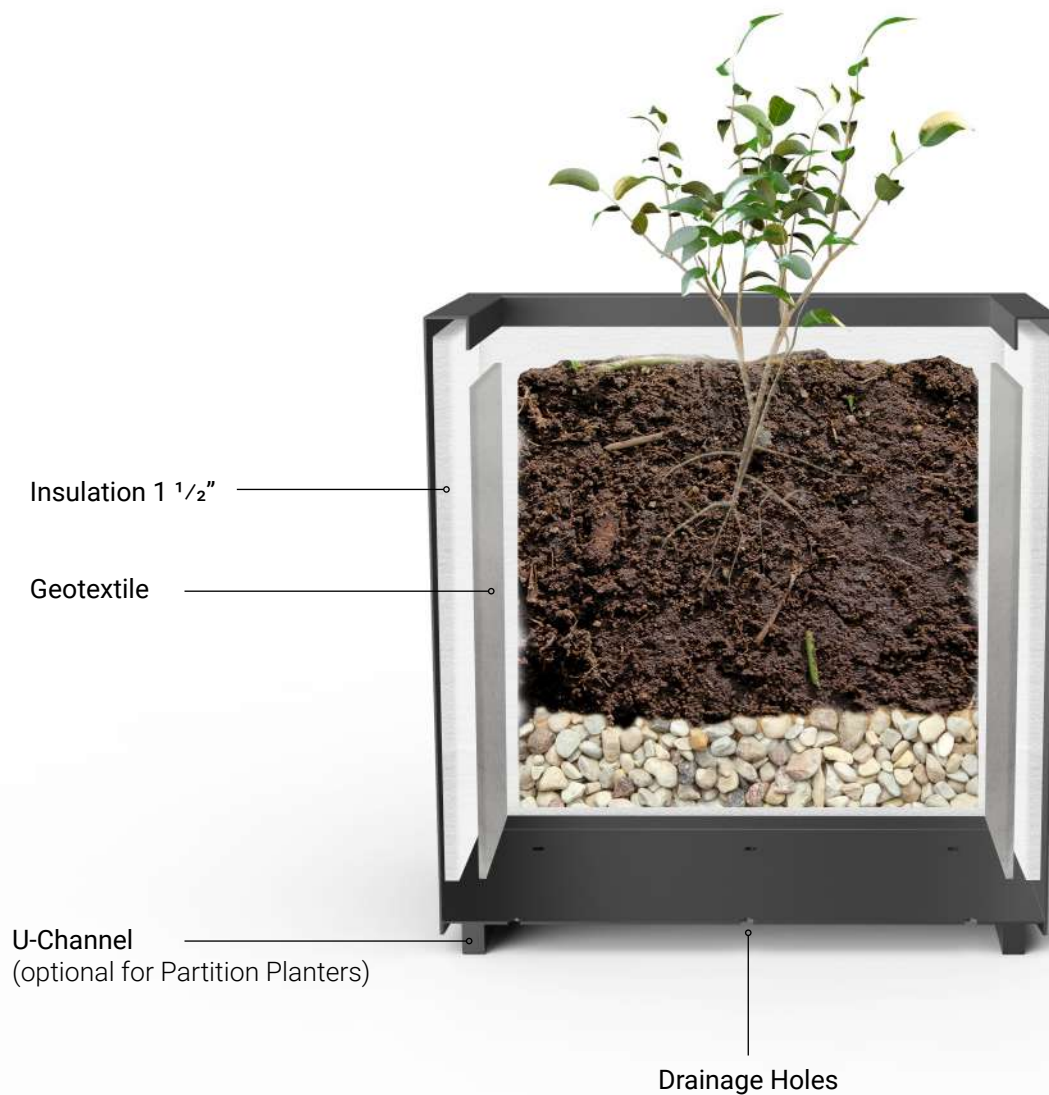

Slatwall Backsplash

Our extruded aluminum modular backsplash system is available in our standard powder coating finishes. Designed to be both aesthetic and functional, these 6" tall panels can be configured to various heights and can house planters and other accessories.

Model	Width	Length
Small Panel (A-SLATWALL-SMALL PANEL)	6"	6" - 48"
Large Panel (A-SLATWALL-LARGE PANEL)	6"	48 1/8" - 96"

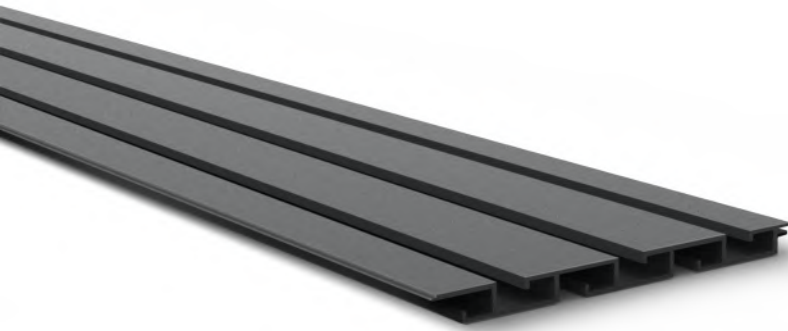

Our backsplash system must be installed against an existing wall or structure. Installation requirements may vary based on site conditions, local codes, equipment specifications and other factors. Check with your local licensed professional to ensure full and complete compliance to codes.



Clip-in Planters

Clip in planter accessory for modular slatwall backsplash. Dimensions L6" x W12" x H6".

Clip-in Planter
(A-CLIPPLANTER)



Utility Hook Kit

304 stainless steel utility hook kit for use with the slatwall backsplash. Set of 6.

Utility Hook Kit
(A-SLATWALL-HOOK-KIT)





COMPATIBILITY

Urban Bonfire™ By Oasis Outdoor Living Custom Designs

Compatible with most major grill and outdoor appliance brands, including:



... and many more.

Urban Bonfire™ By Oasis Outdoor Living Classics

Compatible with a curated selection of grill and outdoor appliance brands, including:





TECHNICAL DETAILS

Cabinet Specifications

Dimensions

The following dimensions apply to all Urban Bonfire™ By Oasis Outdoor Living cabinets. Width varies with cabinet model.

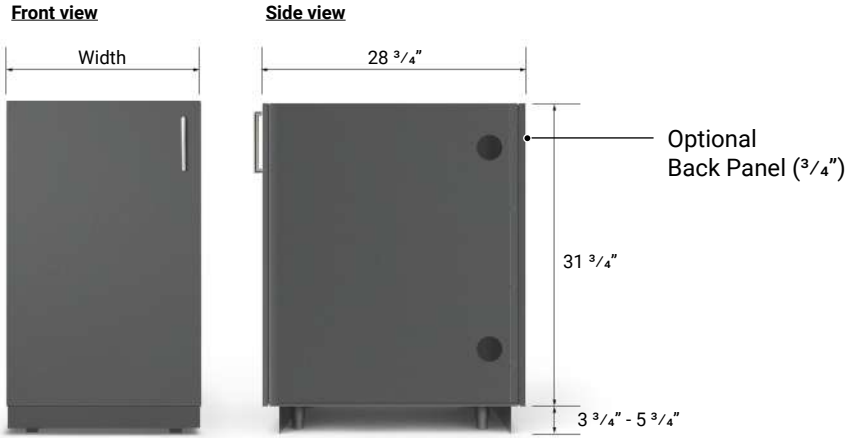

Model name

A-XX00

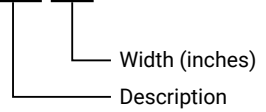

Door Catch
Discrete, heavy duty magnetic catch system.

Insulated Door
Dual panel doors with solid insulated core.

Cabinet Material
Thick marine grade aluminum construction. Super durable powder coating.



Conduits designed to easily connect services (wire, pipes, etc.) between cabinets.

Electrical and Plumbing: Removable Access Panels
Easily remove panel(s) to access outside services.

Hardware
Outdoor grade 304 stainless steel
- Commercial grade leveling legs
- Pulls
- Hinges
- Slides
- Handles

Self-leveling Toe Kick
Adapts to slope and outdoor site conditions. Simple removal and replacement designed for easy cleaning or seasonal maintenance.

URBAN
Bonfire[™]

URBAIN

By OASIS OUTDOOR LIVING

100 Oakdale Road
Johnson City, NY 13790
www.OasisOutdoorLiving.com
1 (844) 627-4758